

LT-54B33B-PG / LT-54B33B-P-AG

(RoHS Compliant)

3.3V / 622 Mbps 1490 nm Continuous-Mode TX / 155 Mbps 1310 nm Burst-Mode RX

ITU-T G.983.3 B-PON CLASS B 2X5 SFF OLT Transceiver

FEATURES

- | Class B Optical Line Terminal (OLT) for ITU-T G.983.3 B-PON
- | 622 Mbps / 1490 nm Continuous-Mode Transmitter
- | 155 Mbps / 1310 nm Burst-Mode Receiver with 2R Output
- | **Resetless** BM Receiver Design
- | BM RX capable of handling Packet-to-packet spacing less than 50 ns for over 15dB packet optical power difference
- | High Resistance of BM RX to DC Optical Background
- | 0 to 70°C Operating: LT-54B33B-PC
- | -20 to 85°C Operating: LT-54B33B-PC-A
- | 2x5 SFF Package with SC/PC Pigtail
- | Single +3.3 V Power Supply
- | RoHS Complaint
- | Transmitter: AC Coupling Input
- | Receiver: DC Coupling Output
- | LVPECL Differential Inputs and Outputs
- | LVTTL TX Shutdown Input
- | LVTTL TX Laser Failure Alarm Output
- | Wave Solderable and Aqueous Washable
- | Class 1 Laser International Safety Standard IEC-60825 Compliant

DESCRIPTION

LT-54B33B series is ITU-T G.983.3 Class B optical line terminal (OLT) for 622 Mbps/1490 nm in downstream and 155 Mbps/1310 nm in upstream. The transmitter section uses a multiple quantum well 1490 nm DFB laser and is a class 1 laser compliant according to International Safety Standard IEC-60825. The receiver section uses an integrated 1310 nm burst-mode detector preamplifier (IDP) mounted in an optical header and a burst-mode limiting post-amplifier IC. **Unlike the conventional BM RX, the RX does not requires reset pulse to receive optical data packets with different optical power.** LVPECL interface is used for differential inputs and outputs. A LVTTL logic interface simplifies interface to external circuitry.

LASER SAFETY

This single mode transceiver is a Class 1 laser product. It complies with IEC-60825 and FDA 21 CFR 1040.10 and 1040.11. The transceiver must be operated within the specified temperature and voltage limits. The optical ports of the module shall be terminated with an optical connector or with a dust plug.

APPLICATIONS

- | B-PON System

ORDER INFORMATION

P/No	Class	TX				RX				Temp (°C)	Package	RoHS Compliant
		Type	Speed (Gb/s)	λ (nm)	Power (dBm)	Type	Speed (Gb/s)	λ (nm)	Sens. (dBm)			
LT-54B33B-PG	B	CNT	622	1490 DFB	4 / -1	BM, 2R	155	1310	-8 / -31	0 / 70	SFF 2X5 Pig.	Yes
LT-54B33B-P-AG	B	CNT	622	1490 DFB	4 / -1	BM, 2R	155	1310	-8 / -31	-20 / 85	SFF 2X5 Pig.	Yes

NOTE: 1. LT-XXXXXX-P-XG, SC/PC pigtail with fiber length 50 cm.

2. BM: Burst Mode; CNT: Continuous Mode; SFF: Small Form Factor Package.

Absolute Maximum Ratings					
Parameter	Symbol	Min	Max	Units	Notes
Storage Temperature	Tstg	-40	85	°C	
Operating Case Temperature	Topr	0	70	°C	LT-54B33B-P
		-20	85		LT-54B33B-P-A
Power Supply Voltage	Vcc	-0.5	3.6	V	

Recommended Operating Conditions					
Parameter	Symbol	Min	Max.	Unit	Units / Notes
Power Supply Voltage	Vcc	3.13	3.47	V	V
Operating Case Temperature	Topr	0	70	°C	LT-54B33B-P
		-20	85		LT-54B33B-P-A
Power Supply Current	I _{CC(TX+RX)}		300	mA	

Note 1: When surrounding temperature is above 60°C, air flow at rate higher than 1m/sec is required.

Transmitter Specifications (0°C < Topr < 70°C, 3.13V < Vcc < 3.47V)

Parameter	Symbol	Min.	Typ.	Max.	Units	Notes
Optical						
Optical Transmit Power	Po	-1		4	dBm	1
Output Center Wavelength	λ	1480		1500	nm	
Output Spectrum Width	$\Delta \lambda$			1	nm	-20 dB Width
Side Mode Suppression Ratio	SMSR	30			dB	
Extinction Ratio	E _R	10			dB	
Data Rate			1.244		Gb/s	
Optical Rise Time				1	ns	10% to 90% Values
Optical Fall Time				1	ns	10% to 90% Values
Relative Intensity Noise	RIN			-120	dB/Hz	
Total Jitter				0.55	ns	
Electrical						
Data Input Current – Low		-350			μA	
Data Input Current – High				350	μA	
Differential Input Voltage	V _{IH} - V _{IL}	150		2000	mV	
Data Input Voltage – Low	V _{IL} - V _{CC}	-2.0		-1.58	V	2
Data Input Voltage -- High	V _{IH} - V _{CC}	-1.1		-0.74	V	2
Shutdown Input Voltage -- Low	V _{TSHDN,L}	0		0.8	V	TX Output Disable
Shutdown Input Voltage -- High	V _{TSHDN,H}	2.0		V _{cc}	V	TX Output Enable
Shut Off Time for Tx Shutdown	t _{DIS}		30		μs	

1. Output power is power coupled into a 9/125 μm single mode fiber.
2. These inputs are compatible with 10K, 10KH and 100K ECL and LVPECL inputs.

Receiver Characteristics (0°C < Topr < 70°C, 3.13V < Vcc < 3.47V)

Parameter	Symbol	Min.	Typ.	Max.	Units	Notes
Optical						
Sensitivity	Sen			-31	dBm	3
Saturation Optical Power	Sat	-8			dBm	3
Wavelength of Operation		1260		1360	nm	4
Data Rate			155		Mb/s	
Packet-to-Packet Spacing		50			ns	5, 6
DC Optical Tolerance		Sen +3			dB	
Optical Return Loss		20			dB	
Electrical						
Data Output Voltage – Low	V _{OL} - V _{CC}	-2.0		-1.58	V	7
Data Output Voltage – High	V _{OH} - V _{CC}	-1.1		-0.74	V	7
Rest Between Packet					Resetless	

3. Sensitivity and saturation levels at BER 1E-10 for a 2²³-1 @ER=10.
4. At least 30 dB optical isolation for the wavelength 1480 to 1500 nm.
5. No reset is needed.
6. The optical power difference between neighboring packets is up to 15 dB.
7. These inputs are compatible with 10K, 10KH and 100K ECL and LVPECL outputs.

BM CLOCK & DATA RECOVERY

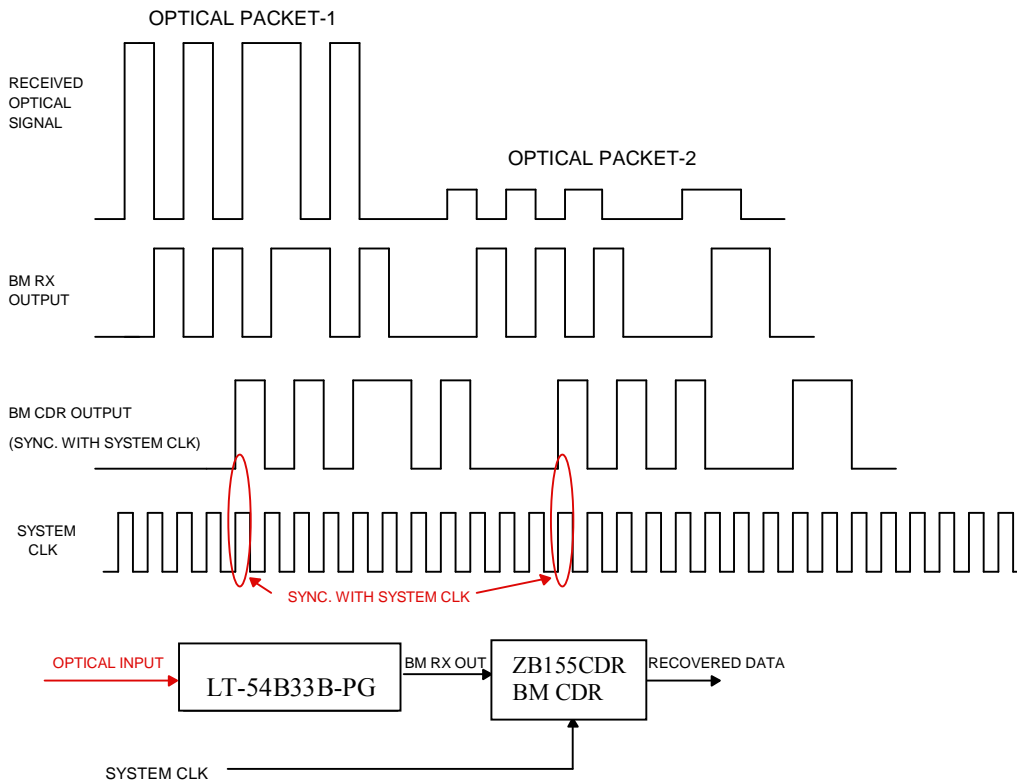

CONNECTION DIAGRAM

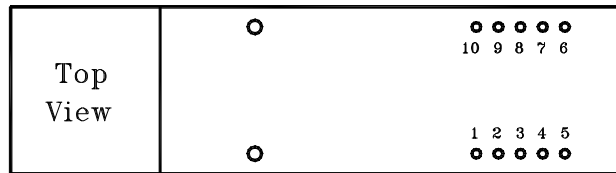

PIN	Signal Name	Description	PIN	Signal Name	Description
1	RX Ground	Receiver Ground. Connect this pin to ground plane.	10	TD-	Negative transmitter data In. Internally terminated for LVPECL. AC coupled.
2	RX Vcc	RX power supply input. Connect to 3.3 V power supply	9	TD+	Positive transmitter data In. Internally terminated for LVPECL. AC coupled.
3	NC	No connection	8	TxDIS	Transmitter Disable. TX is disabled when this pin is low. Internally pulled to "High"..
4	RX OUT (-)	Negative RX output, Differential LVPECL. DC coupled.	7	TX Ground	Transmitter Ground. Directly connect this pin to ground plane
5	RX OUT (+)	Positive RX output, Differential LVPECL. DC Coupled.	6	TX Vcc	TX power supply input. Connect to 3.3 V power supply
MS	MS	Mounting Studs. Connect to Chassis Ground			

RECOMMENDED CIRCUIT SCHEMATIC

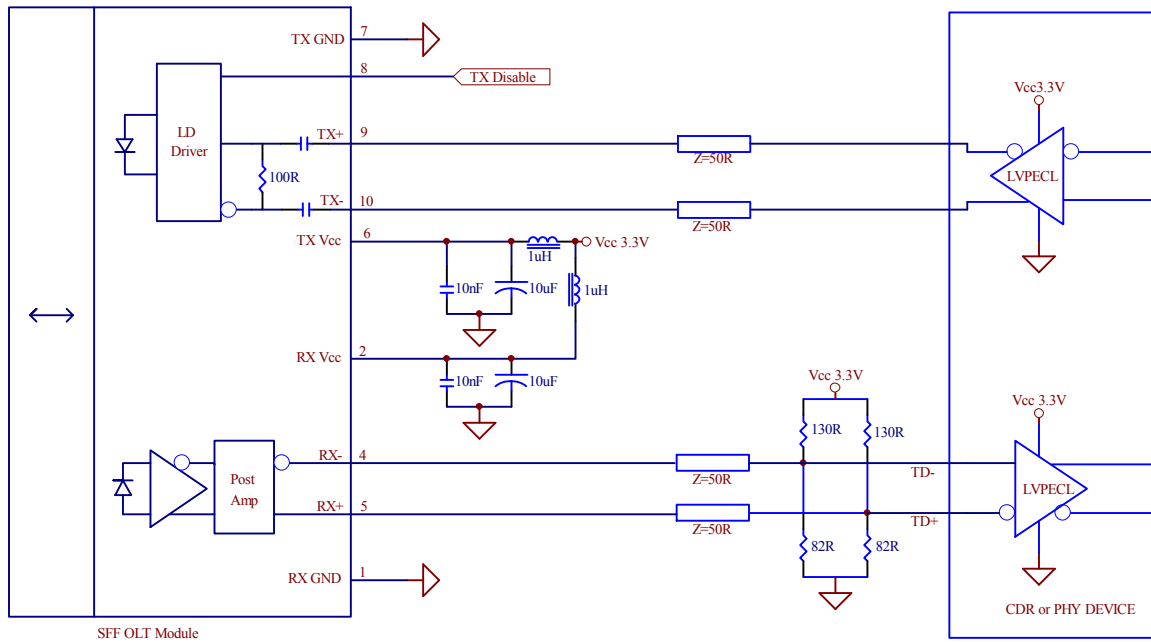

PACKAGE DIAGRAM

Units in mm

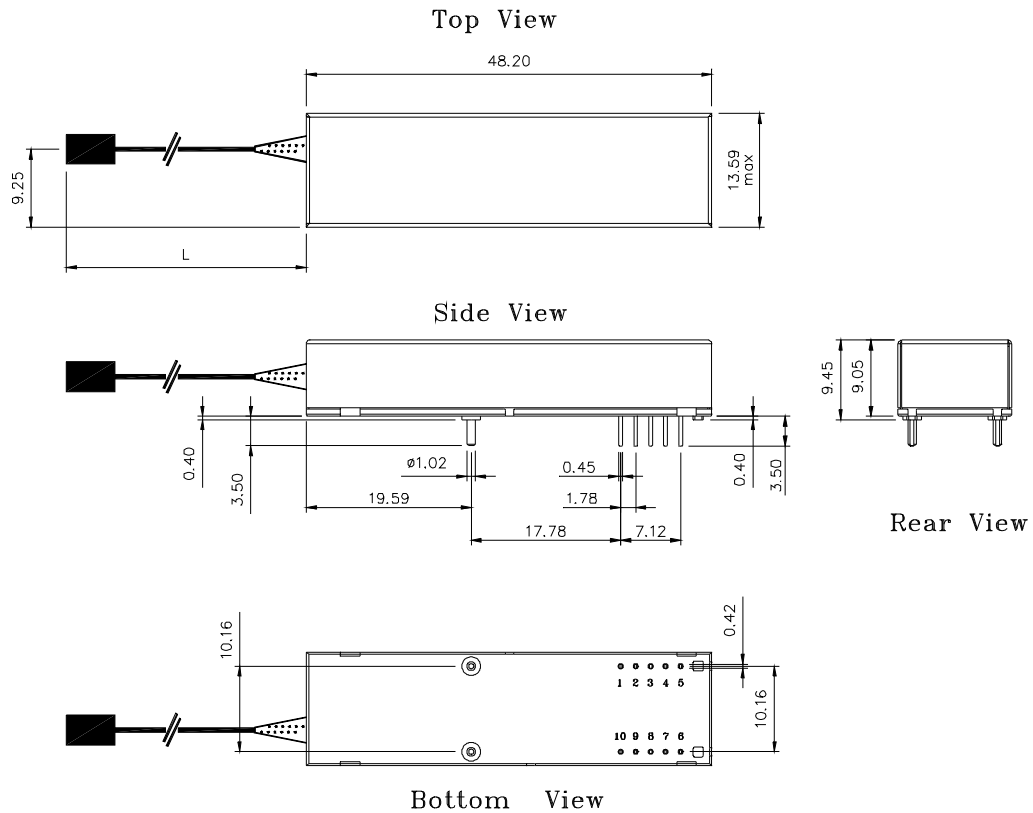

Note: Specifications subject to change without notice. The 50 +/- 3 cm long pigtail with a SC/PC connector is standard. If non-standard pigtail is required, please make a contact with Optoway Technology Inc.

RECOMMENDED CIRCUIT BOARD LAYOUT

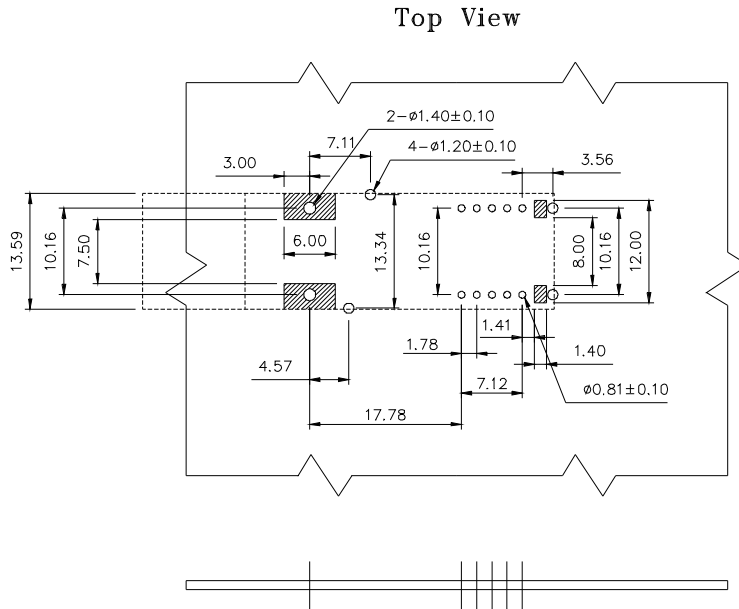

Notes:

1. This figure describes the recommended circuit board layout for the SFF OLT Transceiver.
2. The hatched areas are keep-out areas reserved for housing standoff. No metal traces or ground connection in keep-out area.
3. The mounting studs should be solder to chassis ground for mechanical integrity.