



## PROFA™ Pitch Reducing Optical Fiber Array – One-Dimensional (1D)

Pitch Reducing Optical Fiber Arrays (PROFAs) provide low loss coupling between standard optical fibers and photonic integrated circuits.

Unlike typical fiber arrays, they also provide high density coupling that minimizes the valuable chip real estate needed for optical input/output (I/O). They can provide spot size conversion between small cross-section, chip-based waveguides and standard optical fibers.

One-dimensional (1D) PROFAs are available in standard linear arrays of one to six channels and are typically used for chip edge coupling to waveguides with approximately 2  $\mu\text{m}$  diameter mode field sizes.

[Two-dimensional \(2D\) PROFAs](#) are typically used for chip face coupling to vertical grating couplers with mode field diameters of 9-11  $\mu\text{m}$  or to chip-based devices such as VCSELs or photodiodes. Standard 2D PROFAs are available as hexagonal lattice arrays with up to 61 channels.

Please speak to us about other mode field sizes and lattice configurations which can be addressed with custom PROFAs.

PROFAs are also used within [coupled and packaged solutions](#) that Chiral Photonics can provide.

For your photonic integrated circuit packaging needs, please be sure to contact us for our Optical Coupling & Packaging Design Guide which contains packaging recommendations to assist in your design work. Please send an e-mail to [OptDesignGuide@chiralphotonics.com](mailto:OptDesignGuide@chiralphotonics.com) and we will get that right out to you.



PROFA 1D – Single Channel



PROFA 1D –  
6-Channel Array



## 1D PROFA Specifications

Please speak to us about your custom or OEM needs. Custom PROFAs have been supplied to address different channel counts, wavelengths and configurations:

PARAMETER	UNIT	SINGLE CHANNEL	6-CHANNEL ARRAY
Central Wavelength <sup>1</sup>	nm	1550	
Mode Field Size <sup>2</sup>	μm	1.9 x 2.1	
Bandwidth	nm	> 50	
Polarization Extinction ratio, PER <sup>3</sup>	dB	≥ 20	≥ 16
Insertion Loss <sup>4</sup>	dB	< 1 dB	
Optical Return Loss <sup>5</sup>	dB	-22 to -24	
Crosstalk	dB	-	≤ -40
Number of Channels		1	6
Channel Spacing	μm	-	12
Maximum Channel Position Deviation <sup>6</sup>	μm	-	0.2
Pigtails <sup>7</sup>		PM, 1 meter long, inside 900 μm furcation tube	PM, 1 meter long, 250 μm coated
Operating Temperature	C	-40 to +85	
Storage Temperature	C	-70 to +85	
Package Type <sup>8</sup>	S H	Standard (see below) Holder (see below)	Standard (see below)

<sup>1</sup> Other wavelengths available upon request.

<sup>2</sup> Measured as  $1/e^2$  intensity.

<sup>3</sup> Polarization extinction ratio, for PM devices. Higher PER available upon request. Polarization axis aligned with array axis. Customer can define whether slow axis of pigtails is aligned with  $T_E$  or  $T_M$ .

<sup>4</sup> Measured from fiber pigtail to device endface, per channel.

<sup>5</sup> Intrinsic to device.

<sup>6</sup> Measured relative to “perfect array” channel position.

<sup>7</sup> Other pigtails (e.g. SM), connectorization and other pigtail lengths available upon request.

<sup>8</sup> Please speak to us about your custom package and splicing needs.



# Chiral Photonics

Tel: 973-732-0030 sales@chiralphotonics.com

## PROFA Benefits

**Form Factor/High Density:** Typical lenses cannot be packed closer than 125 microns, compromising the inherent density achievable on-chip. This advantage becomes even more compelling when an arrayed interconnect is of interest.

**Polarization:** Many waveguides are polarization sensitive and maintaining polarization through a lens to small waveguides is challenging if not impossible.

**Robust connection:** PROFAs are intended to be butt coupled. No air gap eliminates the effects of thermal excursions in the package and dust that can make its way into the optical path. The monolithic all-glass construction enables sealing via adhesives or glass or solder (with metallization) for hermiticity, as needed.

**Cost:** In addition to performance advantages, the PROFA is competitively priced in volume quantities.

## Technology Comparison

TECHNOLOGY	APPLICATION REQUIREMENT				
	Mode Field Size $\leq 1 \mu\text{m}$	Adaptable mode field profile	Polarization Maintenance	Wide Bandwidth	Cost Effective
Lensed fiber	X	X	X	✓	✓
On-chip spot size converter	✓	✓	✓	✓	X
Second order grating	✓	-	-	X	✓
Tapered standard fiber	X	X	X	✓	✓
Lensed fiber + On-chip spot size converter		✓	X	✓	X
PROFA	✓	✓	✓	✓	✓



# Chiral Photonics

Tel: 973-732-0030 sales@chiralphotonics.com

## Ordering Information

PROFA1D -  $\lambda$  - CC/SS - PT - CON - H - C

### Options

$\lambda$	Central Wavelength	Standard:	1550 nm
		Custom:	www = customer specified: 800-2000 nm
CC/SS	Array Specifications	Standard:	Number of Channels (CC) = 06 Channel Spacing (SS) = 12 $\mu$ m
		Custom:	ccss = customer specified: cc = no. of channels, ss: channel spacing
PT	Pigtails	Standard:	PMXX = polarization maintaining (PANDA), XX meter long SMXX = singlemode, XX meter long
		Custom:	ttl = customer specified: tt = fiber type, ll = pigtail length
CON	Connectors	Standard:	FC/UPC, FC/APC, LC/UPC or LC/APC (specify)
		Custom:	CC/CCC = customer specified
H	Holder		H = holder option
C		Custom	C = denotes any custom feature, including all connectors and holder

### Examples

PROFA1D-1550-01/00-PM01:

1D PROFA, 1550 nm central wavelength, single channel, PM pigtail – 1 meter long

PROFA1D-1310-01/00-PM02-FC/APC-C:

1D PROFA, 1310 nm central wavelength, single channel, PM pigtail – 2 meter long, custom

PROFA1D-1480-01-/00-SM01-H-C:

1D PROFA, 1480 nm central wavelength, single channel, SM pigtail – 1 meter long, holder, custom

PROFA1D-1550-06/12-PM01

1D PROFA, 1550 nm central wavelength, Array: 6 channel, 12  $\mu$ m channel spacing, PM pigtail – 1 meter long



## Technical Notes

**Cleaning and Care:** PROFAs are all-glass and, therefore, can be cleaned with alcohol much like a bare fiber tip. Care must be taken to avoid breaking or chipping the tip as any damage to the tip will likely cause the device to be unusable.

**Holder:** The holder, shown in the drawing below, is designed to simplify holding of the PROFAs by providing a 6.35 mm shaft compatible with standard fiber chuck holding products.

**Alignment and Coupling:** The device is aligned similarly to other micro-optic devices, e.g. similar to working with lensed fibers. Using the PROFAs, the most efficient and stable coupling is achieved by butt coupling the device to the waveguide. Often customers will use index matching liquids or adhesives but this is not required.

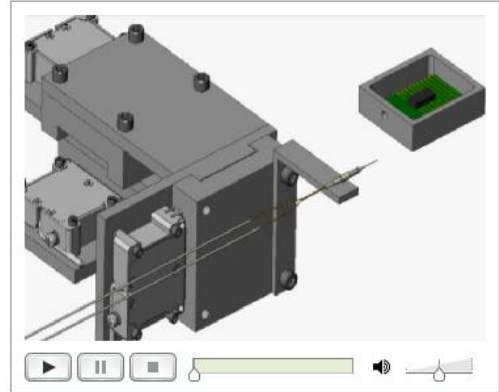

Alignment of PROFAs animation

**Rough Alignment:** Initial rough rotational alignment of the single channel 1D PROFAs is easiest done in the far field using a 1550 nm laser and projecting onto an infrared visualizer. One can use this to achieve rough alignment of the device inside a chuck, for example, to the device's slow/long axis (shorter axis in the far-field). The device is then ready to be aligned finely to, for example, a waveguide.

For the 1D PROFAs array, shown in the drawing below, rough axial alignment can be done by visually aligning the flats that are parallel to the channel array axis.

**Fine Alignment:** A five axis stage with at least +/-0.1 micron resolution is typically used for XYZ motion as well as angular alignment. The needed stage resolution will depend on the mode field sizes one is working with and the application. A general rule of thumb is 10% of the mode field diameter, or 0.2  $\mu\text{m}$  for a standard 1D PROFAs. For an example of one customer's measured stage resolution requirements of 0.3 microns, please see C. R. Doerr, et al., "Tapered Dual-Core Fiber for Efficient and Robust Coupling to InP Photonic Integrated Circuits", OFC Proceedings (2009).

The graphs to the right show simulated coupling losses for alignment of the PROFAs to a mode field matched waveguide when the PROFAs and waveguide are parallel (top) and perpendicular (bottom). Although the PROFAs is designed to be butt-coupled to the waveguide, these simulations show the contribution from a gap (in this case filled with an index matched material,  $n=2$ ) to coupling losses.

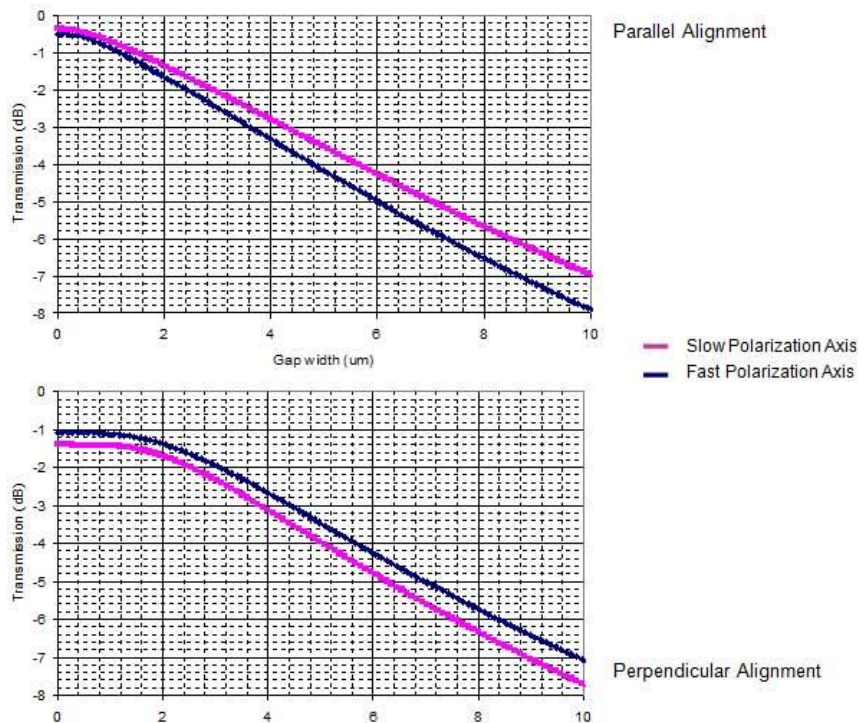



## Dimensional Drawings

### Single Channel

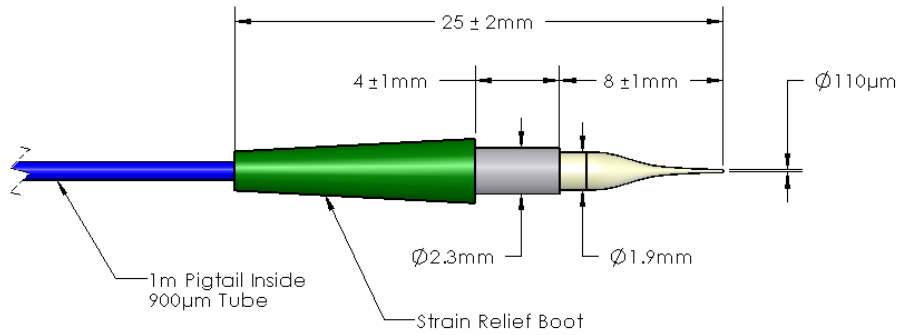

### Single Channel with Holder

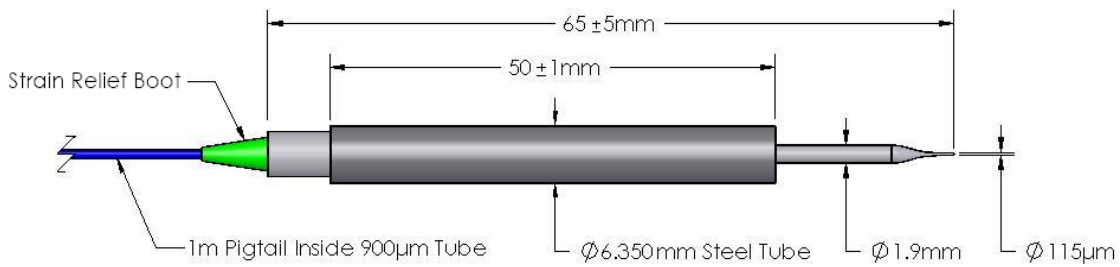

### Array

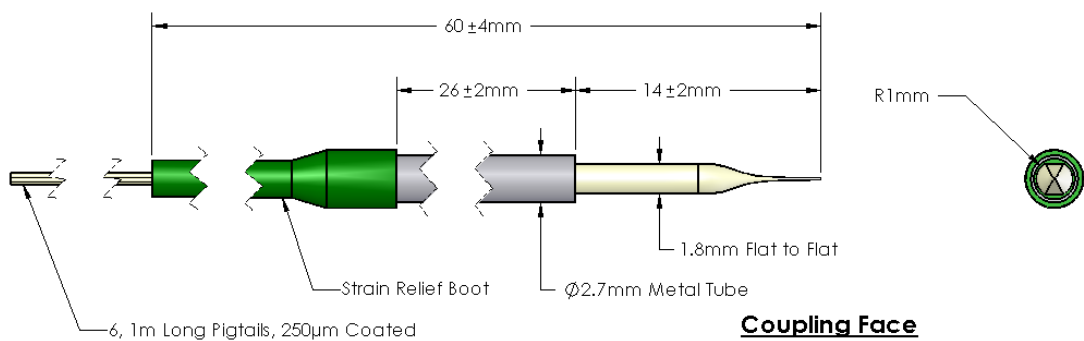

### Coupling Face

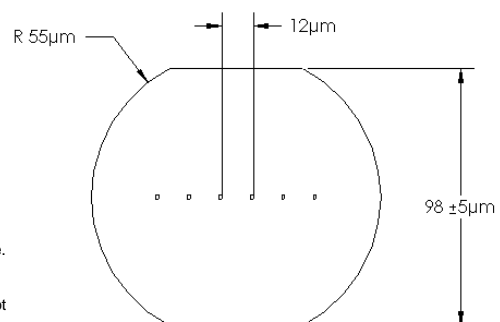

All information contained herein is believed to be accurate and is subject to change without notice. No responsibility is assumed for its use. Chiral Photonics, Inc., its subsidiaries and affiliates, or manufacturer, reserve the right to make changes, without notice, to product design, product components, and product manufacturing methods. Some specific combinations of options may not be available. Please contact Chiral Photonics, Inc. for more information.  
©Chiral Photonics, Inc. All rights reserved. 8/2014