

10 GB/s 10Km CWDM SFP+ Transceivers

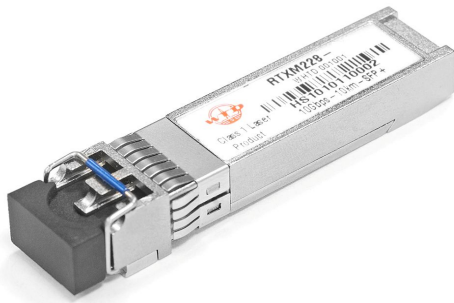

The RTXM228-5XX 10Gigabit DFB laser with CWDM transceiver is designed to transmit and receive serial optical data links up from 8.5 Gb/s to 10.52 Gb/s data rate over 10km singlemode fiber. The Transceiver is compliant with SFF-8432, 10GFC, FC-PI-4, IEEE802.3ae and applicable portions of SFF-8431. Digital diagnostics functions are available via a 2-wire serial interface, as specified in SFF-8472.

Specifications

(tested under recommended operating conditions, unless otherwise noted)

Parameter	Symbol	Unit	Min	Typ	Max	Note
Transmitter						
Nominal Wavelength	λ	nm	1271,1291,1311,1331, The confirmation of the else wavelength is according to the future study.			CWDM
Wavelength Drift	$\Delta \lambda$	nm	-6.5		+6.5	
Side Mode Suppression Ratio	SMSR	dB	30			
Optical Output Power	P_{AV}	dBm	-2.4		+5	1
Extinction Ratio	ER	dB	3.5			
Average launch power of OFF transmitter	P_{OFF}	dBm			-35	
Relative Intensity Noise	RIN	dB/Hz			-128	
Optical Return Loss Tolerance	ORLT	dB			12	
Receiver						
Center Wavelength	λ	nm	1260		1610	
Average Receiver Power	P_{AVG}	dBm	-14.4		+0.5	2
Receiver Sensitivity (OMA)	R_{SENSE1}	dBm			-12.6	2
Stressed Receiver Sensitivity (OMA)	R_{SENSE2}	dBm			-10.3	3
Receiver Reflectance	R_{REFL}	dB			-12	
Assert LOS	LOS_A	dBm	-30			
De-Assert LOS	LOS_D	dBm			-15	
LOS Hysteresis		dB	0.5			

Note 1: Demand of customer

Note 2: Sensitivity for 10G PRBS 2³¹-1 and BER better than or equal to 10E-12

Note 3: The stressed sensitivity value in the table are for system level BER measurements which include the effects of CDR circuit.

Features

- Link lengths at 10G 10Km
- LC duplex connector
- Low power consumption <1.0W
- 0°C to 70°C operating temperature range
- Single +3.3V±5% power supply
- Digital Monitoring SFF-8472 compliant
- High sensitivity PIN photodiode and TIA
- Uncooled directly modulated DFB Laser with CWDM wavelengths

Applications

- 10GBASE-LR/LW 10G Ethernet
- 10GFC
- 8GFC

Standards

- IEEE 802.3ae
- SFF-8431 Rev 3.0
- SFF-8472 Rev 10.2
- 10GFC Rev 4.0
- FC-PI-4 Rev 7.0

10 GB/s 10Km CWDM SFP+ Transceivers

Ordering Information

Part No.	Specifications									Application
	Package	Data rate(Gb/s)	Laser	Optical Power (dBm)	Detector	Sensitivity (OMA) dBm	Top	Reach (km)	Other	
RTXM228-5XX	SFP+	8.5 ~10.52	CWDM DFB	-2.4 ~+5	PIN	< -12.6	0~70 °C	10km	DDM	10GBASE-LR/LW 8G/10GFC

Part NO.	Wavelength(nm)		
	min	type	max
RTXM228-501	1263.5	1271	1278.5
RTXM228-502	1283.5	1291	1298.5
RTXM228-503	1303.5	1311	1318.5
RTXM228-504	1323.5	1331	1338.5

Absolute Maximum Ratings

Parameter	Symbol	Unit	Min	Max
Storage Temperature Range	Ts	°C	-40	85
Relative Humidity	RH	%	0	95
Supply Voltage	V _{cc}	V	-0.3	4.0

Recommended Operating Conditions

Parameter	Symbol	Unit	Min	Typ	Max
Operating Case Temperature Range	T _c	°C	0		70
Power Supply Voltage	V _{cc}	V	3.14	3.3	3.46
Bit Rate	BR	Gb/s	8.5		10.52
Bit Error Ratio	BER				10 ⁻¹²
Max Supported Link Length	L	km			10

10 GB/s 10Km CWDM SFP+ Transceivers

Principle diagram

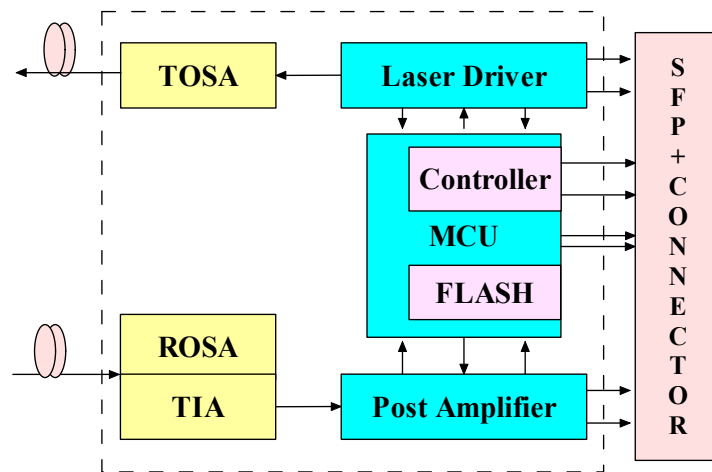

Electric Ports Definition

Parameter	Symbol	Unit	Min	Typ	Max	Note
Supply Voltage	V _{CC}	V	3.14	3.3	3.46	
Supply Current	I _{CC}	mA			300	
Transmitter						
Input Differential Impedance	R _{IN}	Ω	80	100	120	1
Differential Data Input Swing	V _{IN}	mVp-p	180		700	
Transmit Disable Voltage	V _{DIS}	V	2		V _{CCHOST}	
Transmit Enable Voltage	V _{EN}	V	V _{EE}		V _{EE} +0.8	
Transmit Fault Assert Voltage	V _{FA}	V	2.2		V _{CCHOST}	
Transmit Fault De-Assert Voltage	V _{FDA}	V	V _{EE}		V _{EE} +0.4	
Receiver						
Differential Data Output Swing	V _{OD}	mVp-p	450	600	850	
Output Rise Time	t _{RISE}	ps	25			
Output Fall Time	t _{FALL}	ps	25			
LOS Fault	V _{LOSFT}	V	2		V _{CCHOST}	
LOS Normal	V _{LOSNR}	V	V _{EE}		V _{EE} +0.8	

NOTE 1: Differential between TD+ / TD-

10 GB/s 10Km CWDM SFP+ Transceivers

Pin function definitions

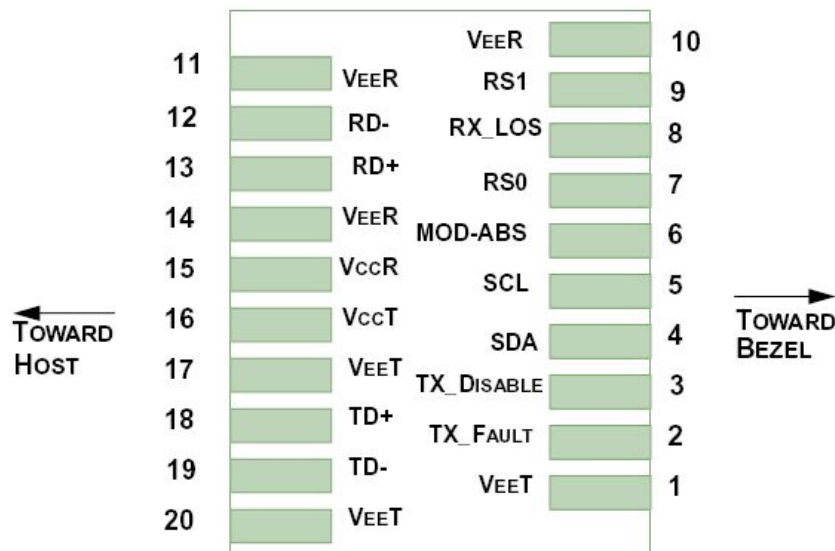

Pin Number	Symbol	Name	Description
1,17,20	VeeT	Transmitter Signal Ground	These pins should be connected to signal ground on the host board.
2	TX Fault	Transmitter Fault Out (OC)	Logic "1" Output = Laser Fault (Laser off before t_fault) Logic "0" Output = Normal Operation This pin is open collector compatible, and should be pulled up to Host Vcc with a 10kΩ resistor.
3	TX Disable	Transmitter Disable In (LVTTTL)	Logic "1" Input (or no connection) = Laser off Logic "0" Input = Laser on This pin is internally pulled up to VccT with a 10 kΩ resistor.
4	SDA	Module Definition Identifiers	Serial ID with SFF 8472 Diagnostics Module Definition pins should be pulled up to Host Vcc with 10 kΩ resistors.
5	SCL		
6	MOD-ABS		
7	RS0	Receiver Rate Select (LVTTTL)	These pins have an internal 33kΩ pull-down to ground. A signal on either of these pins will not affect module performance.
9	RS1	Transmitter Rate Select (LVTTTL)	
8	LOS	Loss of Signal Out (OC)	Sufficient optical signal for potential BER < 1x10 ⁻¹² = Logic "0" Insufficient optical signal for potential BER < 1x10 ⁻¹² = Logic "1" This pin is open collector compatible, and should be pulled up to Host Vcc with a 10kΩ resistor.
10,11,14	VeeR	Receiver Signal Ground	These pins should be connected to signal ground on the host board.
12	RD-	Receiver Negative DATA Out (CML)	Light on = Logic "0" Output Receiver DATA output is internally AC coupled and series terminated with a 50Ω resistor.
13	RD+	Receiver Positive DATA Out (CML)	Light on = Logic "1" Output Receiver DATA output is internally AC coupled and series terminated with a 50Ω resistor.

10 GB/s 10Km CWDM SFP+ Transceivers

15	VccR	Receiver Power Supply	This pin should be connected to a filtered +3.3V power supply on the host board. See Figure 3. Recommended power supply filter
16	VccT	Transmitter Power Supply	This pin should be connected to a filtered +3.3V power supply on the host board. See Figure 3. Recommended power supply filter
18	TD+	Transmitter Positive DATA In (CML)	Logic "1" Input = Light on Transmitter DATA inputs are internally AC coupled and terminated with a differential 100Ω resistor.
19	TD-	Transmitter Negative DATA In (CML)	Logic "0" Input = Light on Transmitter DATA inputs are internally AC coupled and terminated with a differential 100Ω resistor.

Typical Application Circuit

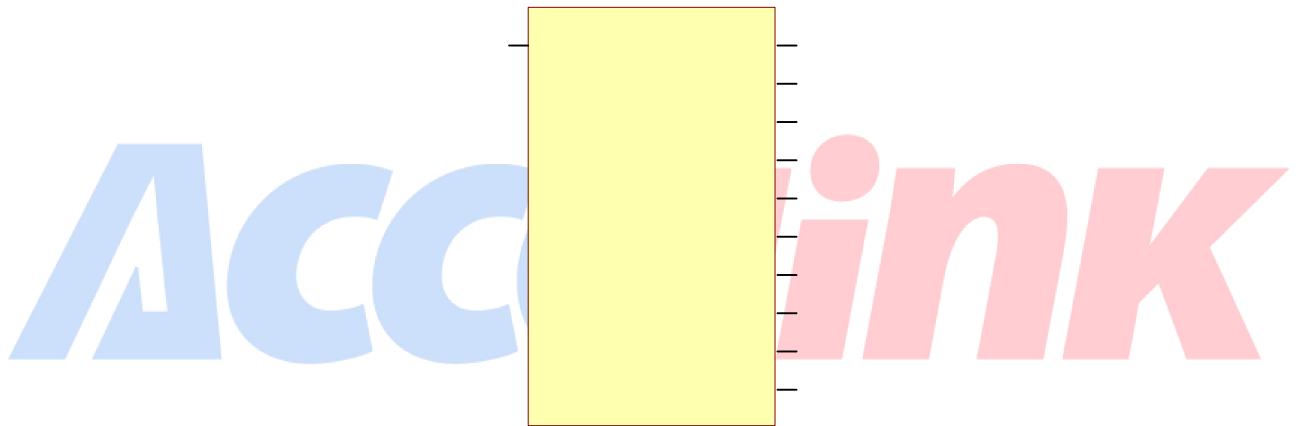

10 GB/s 10Km CWDM SFP+ Transceivers

Package Outline

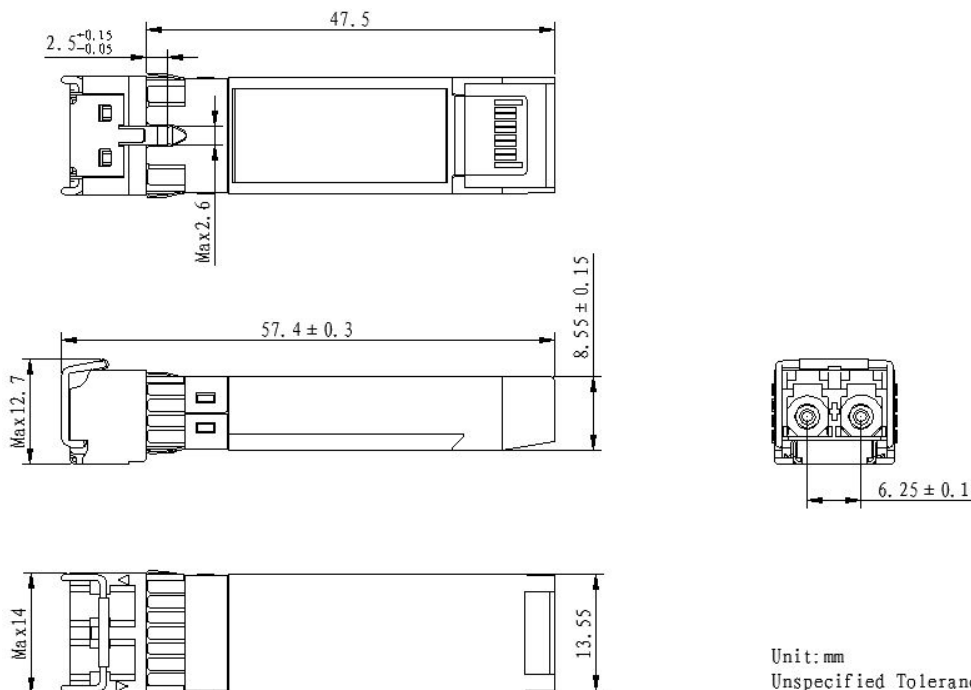

Regulatory Compliance

Feature	Test Method	Performance
Electrostatic Discharge (ESD) to the Electrical Pins	MIL-STD-883C Method 3015.7	Class 1 (> 1500 Volts)
Electrostatic Discharge (ESD) Immunity	Variation of IEC 61000-4-2	LV 4(Air discharge :15KV;Contact discharge:8 KV) Performance criterion:B
Electromagnetic Interference (EMI)	CISPR22 ITE Class B EN55022 Class B FCC Class B	Compliant with standards
Immunity	IEC61000-4-3 Class 2 EN55024	Typically show no measurable effect from a 3V/m field swept from 80 to 100MHz applied to the transceiver without a chassis enclosure.