



DVI Dual Link Extender via MPO Fiber

Self-EDID Programming
Up to 500m in one Multimode Fiber



Description

APAC's DVI500-MPO2 optical extender provides a high quality and dual uncompressed DVI data link between PC and monitor. Go through the optical fiber technologies, this extender can enable transmission up to **500m in one MPO multimode cable**. The **self-EDID programming** feature is also built-in to make the field installation more easy and flexible.

Features

- Long distance image transmission
- High resolution and quality
- No RF interference by optical fiber
- Class 1 laser product complies with EN 60825-1
- CE/FCC certifications for EMI/RFI

Application

- Remote monitor for traffic, industrial and military control
- LCD, projector and plasma display connection
- Large video wall system
- Multi-monitors for advertising

Ordering information

Part Number	Description
DVI500-MPO2-T- <u>XX</u>	Transmitter side
DVI500-MPO2-R- <u>XX</u>	Receiver side
DVI500-MPO2- <u>XX</u>	Transmitter + Receiver
	<u>XX</u>
	00: US Plug for AC adaptor
	01: EU Plug for AC adaptor
	02: BS Plug for AC adaptor
	03: AU Plug for AC adaptor

* This product does not include optical fibers

Application

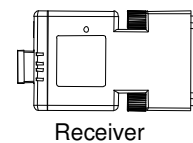
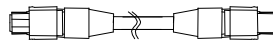
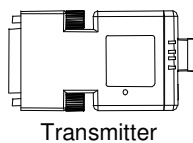



DVI Dual Link Extender via MPO Fiber

Self-EDID Programming

Up to 500m in one Multimode Fiber

Specification

PARAMETER	SPECIFICATION	NOTE
Maximum resolution	Dual Link (2560 × 1600)	
Maximum transmission distance	500m	50/125 μ m multimode MPO fiber Use 62.5/125 μ m multimode fiber may reduce the maximum transmission distance.
EDID support	Self-EDID programming	
HDCP compliant	Not available	
Operating voltage	DC 5V	
Supply current	150mA 250mA	TX module RX module
Optical connector	MPO connector	
Recommended fiber	50/125 or 62.5/125 μ m multimode fiber	
Operating temperature	0 °C ~ 50 °C	
Storage temperature	-20 °C ~ 65 °C	
Dimension	TX unit : 68.7 x 39.3 x 15 RX unit : 68.7 x 39.3 x 15	L × W × H (mm)
Weight	TX unit : 96 g ; RX unit : 96 g	

Package include

- TX module × 1
- RX module × 1
- 5V adapter × 2

Optional : DVI cable 、 EU/BS/AU Plug converter of 5V adapter

MPO Cable Fiber Assignment

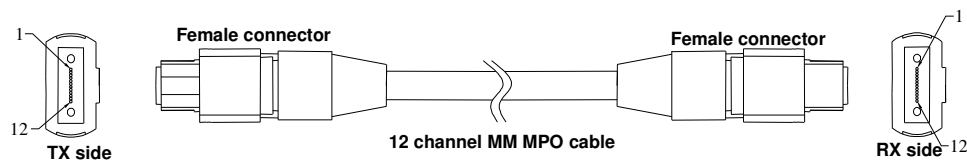



DVI Dual Link Extender via MPO Fiber

Self-EDID Programming

Up to 500m in one Multimode Fiber

Adaptor Specification

PARAMETER	SPECIFICATION	NOTE
Input	100~240 VAC, 50~60 Hz	
Output	DC 5V, 2A	
DC Jack	Inside 5V / Outside ground	



US Plug



EU Plug



BS Plug



AU Plug



DVI Dual Link Extender via MPO Fiber

Self-EDID Programming

Up to 500m in one Multimode Fiber

Requirements

- DVI PC or DVI source (Transmitter)
- DVI monitor or projector (Receiver)
- 100~240 VAC, 50~60 Hz, 0.2A

Self-EDID Programming Function

The EDID in a display can be read and restored by just plugging it to the display. This self-EDID programming feature makes the installation of DVI500-MPO2 more easy and flexible at any variable resolution display systems. If the display resolution can not meet default EDID stored in transmitter module, user can just follow page7 to perform this function.

Auto Source Detection and Standby Mode in Transmitter Module

The laser diodes are only turned on when +5V voltage is detected at the pin14 of DVI connectors. When DVI source is not detected, the transmitter (TX) module of DVI500-MPO2 will enter standby mode to save power.

Dimensions

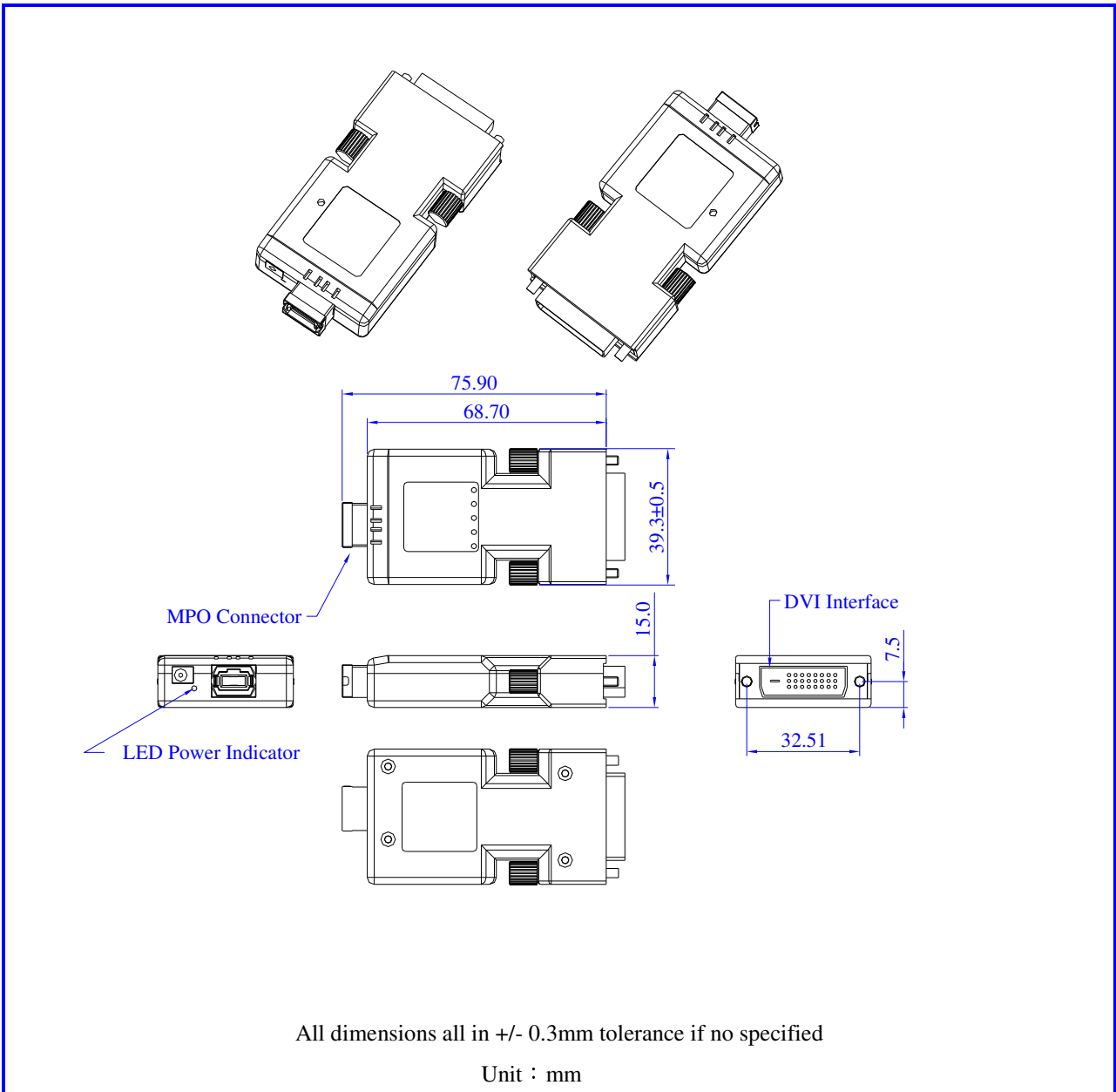

Safety Regulation

CE and FCC approved.



Installation

Please follow the installation procedure below. If the sequence is not correctly, it might bring an improper or undesirable result.

Step 1

Unpack the box and check the contents. You should have the following items.

- TX module × 1
- RX module × 1
- AC/DC Adaptor × 2

Step 2

Plug the 5V power adapter to the power jack of the transmitter. Ensure that the LED beside the power jack is turned on.

Note: You don't need to adopt the AC/DC adapter if the graphic source provides enough power to supply the transmitter module. If the green LED is dim from the normal brightness, please plug the adapter to get enough power.

Step 3

Plug the 5V power adapter to the power jack of the receiver. Ensure that the LED beside the power jack is turned on same as Step 2.

Step 4

Plug one end of the MPO optical cable into the transmitter and plug in the other end into the receiver (See Figure 2).

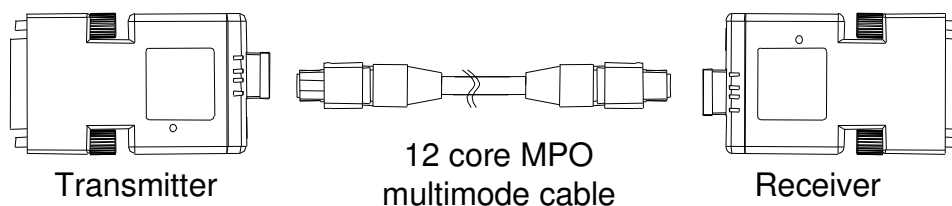

Figure 2

Note: The maximum transmitting distance in multimode fiber is 500m.



DVI Dual Link Extender via MPO Fiber

Self-EDID Programming

Up to 500m in one Multimode Fiber

Step 5

Plug the transmitter to the DVI source such as PC.

Note: Any additional intermediate cable using between transmitter and DVI source might bring undesirable performance degradation.

Step 6

Plug the receiver to the display.

Step 7

Then power on the display and you will see the video pictures. If you can't get the proper resolution on the display, please refer to **Self-EDID Programming Procedure** on page 7 and repeat the installation procedure again.

Note: You can replace any DVI cable by following the **Step1** to **6** while all powers of PC and display are ON.

Self-EDID Programming Procedure

EDID contains resolution and timing information which a display can support. The graphic source equipment generally required to read the EDID from the sink equipment (display). In DVI500-MPO2 series, there is a Default EDID Setting before shipment. Please refer to the “**Default EDID resolution setting**” table on the page 2. This setting stores in the transmitter unit to initiate as a display. Sometimes this default EDID might not contain the resolutions which the display can support and result in an abnormal picture. To solve this problem, DVI500-MPO2 series support a **Self-EDID programming function** which can copy the EDID information from the display. Please follow the steps below to copy the EDID of the display into the transmitter unit.

Step 1

Power on the display.

Step 2

Plug 5V DC power adapter into the transmitter.

Step 3

Connect the transmitter to the display. (Not PC)

Step 4

Push the **self-EDID** button with a narrow pin. The LED will be blinking to indicate the proceeding of copying EDID information. When this LED stopped blinking, the EDID copying procedure is done. (See Figure 3)

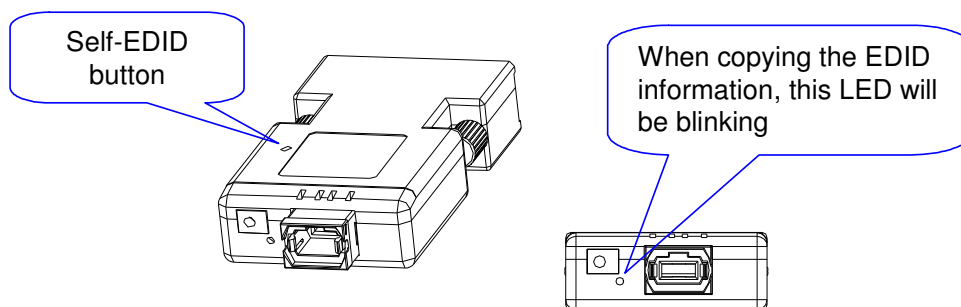

Figure 3 self-EDID Mode

Step 5

Disconnect the transmitter from the display. Follow the **installation procedure** from **step 2 to 7** again and you will get the desired resolution and timing setting.



DVI Dual Link Extender via MPO Fiber

Self-EDID Programming

Up to 500m in one Multimode Fiber

Recovery of default EDID setting

Step 1

Plug 5V DC power adapter into the transmitter and disable all DVI connections (PC and monitor).

Step 2

Push the **self-EDID** button with a narrow pin. The green LED will be blinking to indicate the recovery of EDID information. When this LED stopped blinking, the recovery procedure is done. And, now, the EDID in transmitter has been recovered to the default EDID setting.