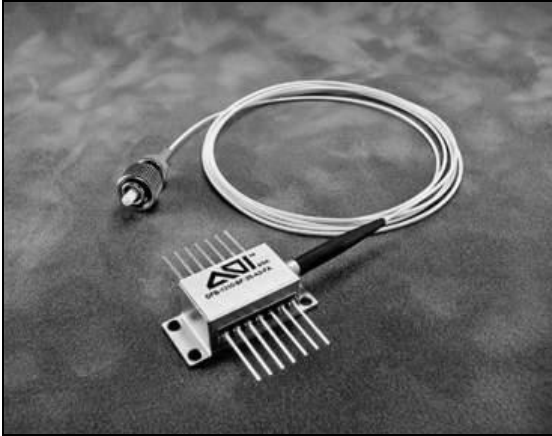

**DFB-XXX-BF-XX-CW-Fx-Hx-N095****Description**

The DFB-1XXX-BF-XX-CW-Fx-Hx-N095 series of Multi-Quantum Well (MQW) Distributed Feedback (DFB) lasers have been designed specifically to satisfy the requirements of the high power, narrow linewidth application.

The devices feature high output power and wide operating temperature range.

Their 14-pin butterfly packages are either pin-compatible with standard SONET OC-48 devices or can be "floating" from the metal house.

**Features**

- ❑ Advanced Multiple Quantum Well (MQW) Distributed Feedback (DFB) Laser Design
- ❑ High-output power
- ❑ Industry-standard 14-pin Butterfly package
- ❑ Option of SMF-28 Fiber Pigtail or PM fiber

**Applications**

- ❑ CATV external modulation
- ❑ DWDM
- ❑ Intermediate and long-distance fiber-optic transmitter



## DFB-XXX-BF-XX-CW-Fx-Hx-N095

### Absolute Maximum Ratings

Parameter	Symbol	Condition	Min	Max	Unit
Operating Case Temperature	$T_c$	$I=I_{op}$	-20	65	°C
Storage Temperature	$T_{stg}$	--	-40	85	°C
Laser Forward Current	$I_f$	--	--	600	mA
Laser Reverse Bias	$V_f$	--	--	2	V
Photodiode Reverse Bias	$V_{rpd}$	--	--	10	V
TEC Current	$I_{TEC}$	$-20\text{ °C} < T_c < 65\text{ °C}$ , $T_{op}=25\text{ °C}$ , $I_f=I_{op}$	--	1.5	A

### Electrical and Optical Characteristics

Parameters are tested at 25 °C unless otherwise noted.

Parameter	Symbol	Min	Typ	Max	Unit	Test Conditions
Operating Case Temperature	$T_c$	-20	--	65	°C	
Laser Set temperature	$T_L$	15	--	35	°C	
Optical Output Power*	$P_o$	25	--	--	mW	CW,
Threshold Current	$I_{th}$	--	--	40	mA	$T_L=25\text{ °C}$
Forward Voltage	$V_F$	--	--	2.5	V	$P_o=P_L$
Operating Current	$I_{op}$	--	--	450	mA	$P_o=P_L$ , $T_L=25\text{ °C}$
Center Wavelength*	$\lambda_c$	Refer to order option			nm	$P_o=P_L$ , CW, $15\text{ °C} \leq T_L \leq 35\text{ °C}$
Center Wavelength Tolerances	$\Delta\lambda_c$	-0.1	--	0.1	nm	$P_o=P_L$ , CW, $15\text{ °C} \leq T_L \leq 35\text{ °C}$
Spectral Line width	$\Delta\lambda$	--	--	1	MHz	$P_o=P_L$ , $T_L=25\text{ °C}$
Polarization Extinction Ratio	PER	18	20		dB	Only with PANDA PM fiber option, slow axis align with E-Field
Optical Isolation	ISO	32			dB	
Side-mode Suppression Ratio	SMSR	30	--	--	dB	$P_o=P_L$
Relative Intensity Noise	RIN			-160	dB/Hz	CW, $T_L=25\text{ °C}$
Monitor Current	$I_{mon}$	9	--	150	$\mu\text{A}/\text{mW}$	$V_{rpd}=5\text{ V}$
Monitor Dark Current	$I_D$	--	--	200	nA	$V_{rpd}=5\text{ V}$
Tracking Error	$\gamma$	-0.5	--	0.5	dB	$I_{mon}=\text{const}$ , $\gamma=10 \log (P_o/P_L)$ [dB]
Thermistor Resistance	$R_t$	9.5	--	10.5	$\text{k}\Omega$	$T=25\text{ °C}$
Thermistor B Constant	B	--	3900	--	K	$T=25\text{ °C}$
TEC Current	$I_c$	--	--	1.5	A	$\Delta T=40\text{ °C}$
TEC Voltage	$V_c$	--	--	4.0	V	$\Delta T=40\text{ °C}$

\* See Ordering Options and contact AOI marketing for availability.

**DFB-XXX-BF-XX-CW-Fx-Hx-N095**

**Outline Diagram**

Dimensions are in millimeters

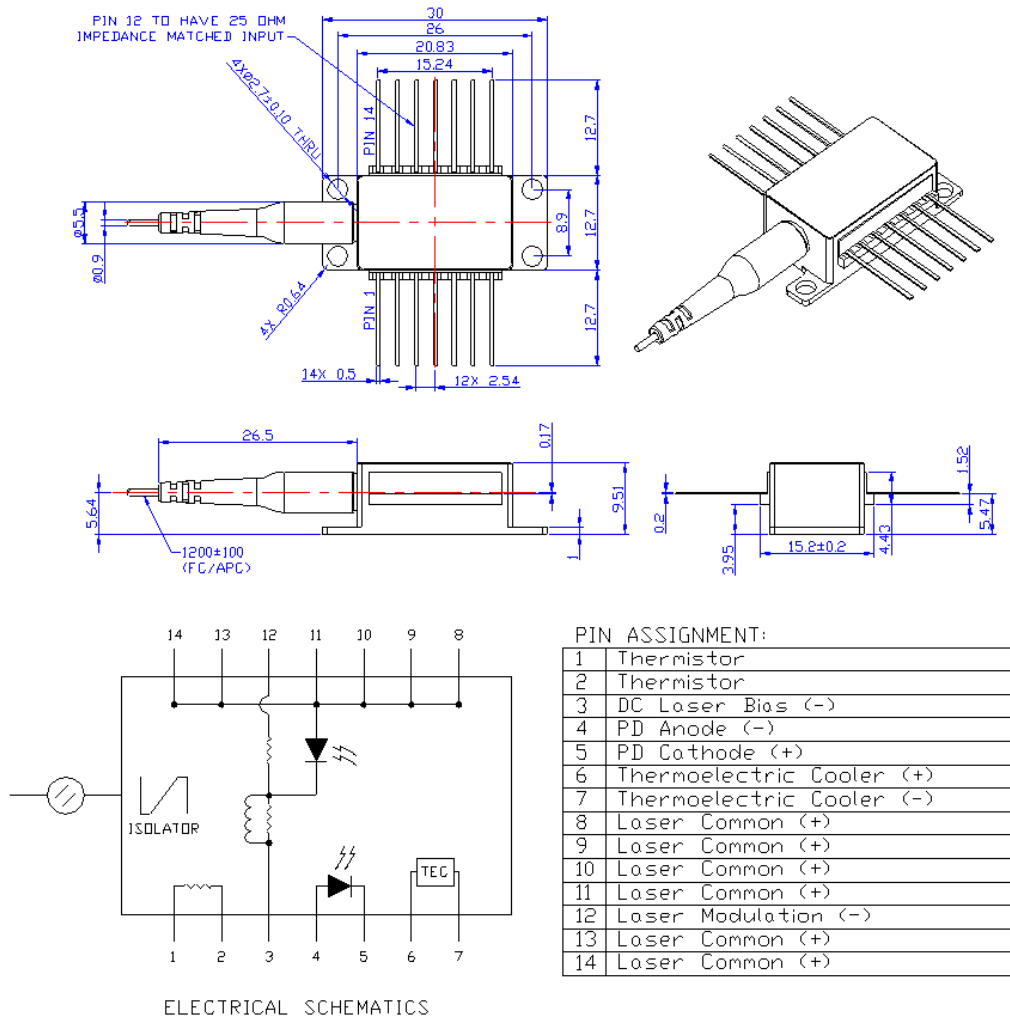

**For ordering option -H1 (Floating LD design)**

**DFB-XXX-BF-XX-CW-Fx-Hx-N095**

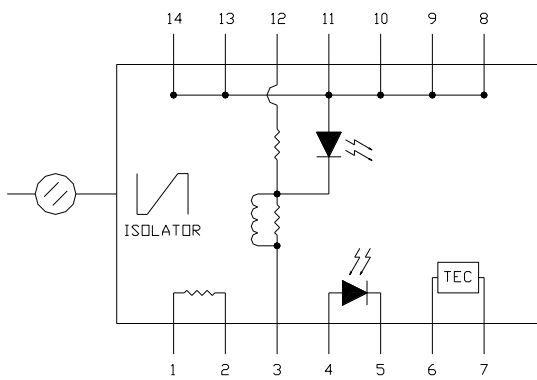
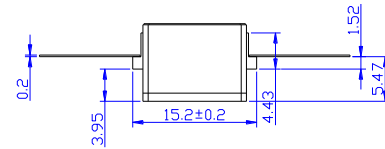
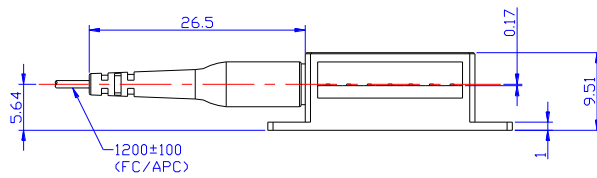
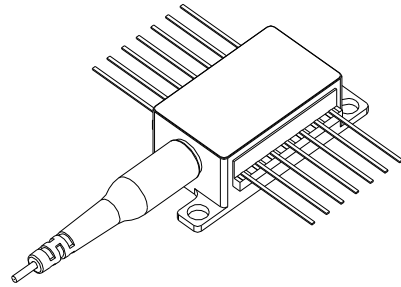
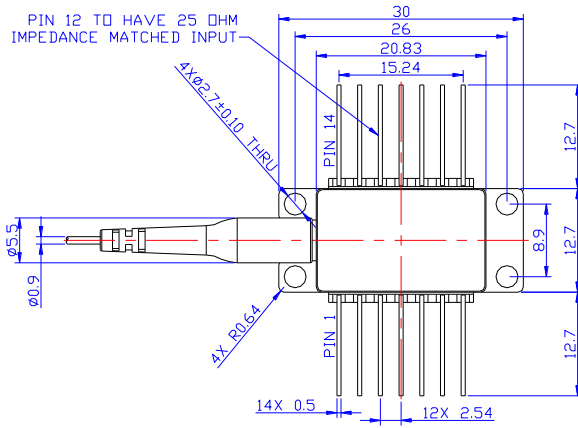

ELECTRICAL SCHEMATICS

PIN ASSIGNMENT:

1	Thermistor
2	Thermistor
3	DC Laser Bias (-)
4	PD Anode (-)
5	PD Cathode (+)
6	Thermoelectric Cooler (+)
7	Thermoelectric Cooler (-)
8	Case Ground
9	Case Ground
10	Case Ground
11	Laser Common (+), Case Ground
12	Laser Modulation (-)
13	Laser Common (+), Case Ground
14	Case Ground

**For ordering option -H2 (Negative Bias Design, Case GRD connected to LD Anode)**

**DFB-XXX-BF-XX-CW-Fx-Hx-N095**

**Ordering Options**

**DFB-XXX-BF-XX-CW-Fx-Hx-N095**

BF House Option :  
 H1 = Floating LD design  
 H2 = Negative Bias Design

Fiber Pigtail Option

Option	Fiber	Length (mm)	Connector	Notes
F1	PM	1200+100	FC/APC	
F2	SMF	1200+100	FC/APC	

Output Power Option

Option	Output Power (mW)	Notes
25	25	decouple
40	40	
50	50	

Wavelength Option  
 Refer to the Channel list below  
Please check with AOI for the channel availability before order

**DFB-XXX-BF-XX-CW-Fx-Hx-N095**
**ITU-T DWDM Channel**

ITU Channel	Frequency (THz)	Wavelength (nm)	Tolerance (nm)	ITU Channel	Frequency (THz)	Wavelength (nm)	Tolerance (nm)
916	191.6	1564.68	± 0.1	940	194.0	1545.32	± 0.1
917	191.7	1563.86	± 0.1	941	194.1	1544.53	± 0.1
918	191.8	1563.05	± 0.1	942	194.2	1543.73	± 0.1
919	191.9	1562.23	± 0.1	943	194.3	1542.94	± 0.1
920	192.0	1561.42	± 0.1	944	194.4	1542.14	± 0.1
921	192.1	1560.61	± 0.1	945	194.5	1541.35	± 0.1
922	192.2	1559.79	± 0.1	946	194.6	1540.56	± 0.1
923	192.3	1558.98	± 0.1	947	194.7	1539.77	± 0.1
924	192.4	1558.17	± 0.1	948	194.8	1538.98	± 0.1
925	192.5	1557.36	± 0.1	949	194.9	1538.19	± 0.1
926	192.6	1556.55	± 0.1	950	195.0	1537.4	± 0.1
927	192.7	1555.75	± 0.1	951	195.1	1536.61	± 0.1
928	192.8	1554.94	± 0.1	952	195.2	1535.82	± 0.1
929	192.9	1554.13	± 0.1	953	195.3	1535.04	± 0.1
930	193.0	1553.33	± 0.1	954	195.4	1534.25	± 0.1
931	193.1	1552.52	± 0.1	955	195.5	1533.47	± 0.1
932	193.2	1551.72	± 0.1	956	195.6	1532.68	± 0.1
933	193.3	1550.92	± 0.1	957	195.7	1531.9	± 0.1
934	193.4	1550.12	± 0.1	958	195.8	1531.12	± 0.1
935	193.5	1549.32	± 0.1	959	195.9	1530.33	± 0.1
936	193.6	1548.51	± 0.1	960	196.0	1529.55	± 0.1
937	193.7	1547.72	± 0.1	961	196.1	1528.77	± 0.1
938	193.8	1546.92	± 0.1	962	196.2	1527.99	± 0.1
939	193.9	1546.12	± 0.1				

## DFB-XXX-BF-XX-CW-Fx-Hx-N095

### Safety Information

All versions of this laser are Class 1M laser products per IEC<sup>1</sup>/EN<sup>2</sup> 60825-1:2001-08. Users should observe safety precautions such as those recommended by ANSI<sup>3</sup> Z136.1-2000, ANSI Z36.2-1997 and IEC 60825-1:2001-08.

#### Notes about Laser Safety Class:

The Food and Drug Administration's Center for Devices and Radiological Health (FDA/CDRH) in the USA has decided to harmonize their requirements with 21 CFR 1040.10 and 1040.11 with the IEC/EN 60825-1 and IEC/EN 60601-2-22 standards. This process has not yet happened and in the interim, the CDRH agency has released '[Laser Notice No.50](#)' to reduce the regulatory burden. This notice allows IEC/EN classification and labeling of lasers within the USA.

#### IEC<sup>1</sup>/EN<sup>2</sup> 60825-1 Laser Class

**Class 1M:** laser is safe for all conditions of use except when passed through magnifying optics such as microscopes and telescopes. Class 1M lasers produce large-diameter beams, or beams that are divergent. The MPE for a Class 1M laser cannot normally be exceeded unless focusing or imaging optics are used to narrow the beam. If the beam is refocused, the hazard of Class 1M lasers may be increased and the product class may be changed. A laser can be classified as Class 1M if the total output power is below (IEC/EN) class 3B but the power that can pass through the pupil of the eye is within Class 1.

#### FDA Laser Class

**Class IIIB:** moderate power lasers (cw: 5-500 mW, pulsed: 10 J/cm<sup>2</sup> or the diffuse reflection limit, whichever is lower). In general Class IIIB lasers will not be a fire hazard, nor are they generally capable of producing a hazardous diffuse reflection. Specific controls are recommended.

This product does not conform to 21 CFR 1040.10 and 1040.11. Consequently, this laser module is only intended for use as a component by manufacturers of electronic products and equipment.

Wavelength = 1270 – 1610 nm  
 Maximum Power = 75mW  
 Single-mode fiber pigtail  
 Fiber Numerical Aperture = 0.14

Labeling is not affixed to the laser module due to size constraints; rather, labeling is placed on the outside of the shipping box.

This product is not shipped with a power supply.

**Caution: use of controls or adjustments or performance of procedures other than those specified herein may result in hazardous radiation exposure.**



classified in accordance with IEC 60825-1: 2001-08

(1) IEC is a registered trademark of the International Electrotechnical Commission

(2) Within Europe the IEC standard has been adopted as a European Normative standard known as EN 60825, and each European country will have its own version of this standard, for example, the British Standards version known as BS EN 60825. There can be small differences between the different countries versions of EN 60825, and these are in part caused by the process of translating the standard into the native language of that country.

(3) ANSI is a registered trademark of the American National Standards Institute.